



**REACH STACKER SPREADERS  
EMPTY CONTAINER HANDLERS  
LADEN CONTAINER HANDLERS**

**BROMMA**

*A Tradition of Innovation*



# FIVE REASONS TO SPECIFY BROMMA SPREADERS

## » 20% LIGHTER COMPARED TO OTHER BRANDS

- Lower weight on the reach stacker
- Lower fuel consumption
- Less wear and tear on tires, power train, transmission and drive train axles

## » PROPORTIONAL CONTROL FOR ALL MOTIONS

- Accurate positioning
- Adjustable damping for all motions
- Eliminates shocks and increases driver's comfort

## » DESIGNED AND BUILT BY BROMMA

- Bromma is the largest spreader maker in the world, with proven R&D record

## » EXTENSIVE AFTER SALES NETWORK AROUND THE GLOBE

## » RELIABLE AND ROBUST, WITH MINIMAL DOWN TIME

*Bromma spreaders understand the terrain of the terminal, and remain productive, reliable, and durable under conditions that are never ideal.*

# RSX40 REACH STACKER SPREADER



*The picture shown is for illustration purpose and may not correspond to the final design.*

- » **LOW TARE WEIGHT FOR HIGH PERFORMANCES**
- » **PROPORTIONAL VALVE CONTROL FOR TELESCOPIC, ROTATING AND SIDESHIFT MOTION**
- » **20' TO 40' AT MAXIMUM SPEED WITH DAMPENING**
- » **FLOATING ISO TWISTLOCKS**
- » **±800MM SIDE SHIFT**
- » **-195°/+105° ROTATION**
- » **±5° MECHANICAL PILE SLOPE**
- » **FULL CANOPEN BUS INTEGRATED MANAGEMENT**
- » **LONGER SERVICE INTERVALS**
- » **LIGHT AND ROBUST WITH WELL PROVEN DESIGN**

The Bromma RSX40 is a spreader designed to handle single 20ft and 40ft containers for reach stacker.

It is one of the lightest spreader in the market, providing unparalleled performances and cost savings.

RSX40 is equipped with side shift, rotating, telescopic, mechanical pile slope and floating twistlock functions that allows it to easily locate containers. All spreader movements are controlled with 24V proportional valves, providing precise and smooth operation.

The spreader is operated from the driver's cab over serial communication (CANopen) or parallel wiring. Commands are processed by an electronic control unit on the spreader with built in safety logics for container handling.

## Technical Data RSX40

### » LIFTING CAPACITY (SWL)

45 metric tons, up to ±10% eccentric load.  
4 x 10 metric tons, with lifting lugs on the endbeams.

### » TARE WEIGHT (TW)

7.700 kg (approximately)  
- without extra equipment.

### » ISO FLOATING TWISTLOCKS

90° in less than 1.5 sec.  
Mechanical and electrical safety interlock system.

### » TELESCOPING

20' to 40' in less than 15 sec.  
Analogue or digital sensors for damping and telescoping.

### » ROTATION

-195°/+105° in less than 45 sec.  
with control technology for smooth positioning.

### » SIDE SHIFT

±800 mm

### » MECHANICAL PILE SLOPE

±5°

### » ELECTRICS

24 V DC control voltage.  
Electronic control unit.  
Serial interface, CAN open according to CiA DS 444 profile.  
2 LED work lights.  
3 indication lights.

### » HYDRAULICS

70-90 l/mn at 160 bar. ISO cleanliness rating 18/16/13 (ISO 4406).

### » SURFACE CONDITIONING

PUR RAL 7021 (black grey) 160/2  
FeSA2.5 with gloss grade 30 +10/-5  
for corrosion protection classification  
C3L/C2M according to EN - ISO 12944.

# RSX40C REACH STACKER COMBI SPREADER



*The picture shown is for illustration purpose and may not correspond to the final design.*

- » **LOW TARE WEIGHT FOR HIGH PERFORMANCES**
- » **SMOOTH CONTROL TECHNOLOGY**
- » **20' TO 40' AT MAXIMUM SPEED WITH DAMPENING**
- » **FLOATING ISO TWISTLOCKS**
- » **GRAPPLE ARMS WITH BLOCK STACKING**
- » **±800MM SIDE SHIFT**
- » **-195°/+105° ROTATION**
- » **±5° POWERED PILE SLOPE**
- » **FULL CANOPEN BUS INTEGRATED MANAGEMENT**
- » **LONGER SERVICE INTERVALS**
- » **FASTER DIAGNOSTICS**
- » **LIGHT AND ROBUST WITH WELL PROVEN DESIGN**

The Bromma RSX40C is a combined reach stacker spreader for single container and trailer handling.

It has four grapple arms to lift trailers, swap bodies (C715, C745) and bottom lifting containers.

RSX40C is equipped with grapple arms, side shift, rotating, telescopic, powered pile slope and floating twistlock functions that allows it to easily locate containers.

All spreader movements are controlled with 24V proportional valves, providing precise and smooth operation.

The spreader is operated from the driver's cab over serial communication (CANopen) or parallel wiring. Commands are processed by an electronic control unit on the spreader with built in safety logics for container handling.

## Technical Data RSX40C

### » LIFTING CAPACITY (SWL)

45 metric tons, up to ±10% eccentric load.  
4 x 10 metric tons, with lifting lugs on twistlocks endbeams.

### » TARE WEIGHT (TW)

12.500 kg (approximately)  
- without extra equipment

### » ISO FLOTING TWISTLOCKS

90° in less than 1.5 sec.  
Mechanical and electrical safety interlock system.

### » GRAPPLE ARMS

2 pairs with block stacking up or down in less than 20 sec.

### » TELESCOPING

20' to 40' in less than 15 sec.  
Analogee or digital sensors for damping and telescoping.

### » ROTATION

-195°/+105° in less than 45 sec.  
with control technology for smooth positioning.

### » SIDE SHIFT

±800 mm

### » POWERED PILE SLOPE

±5°

### » ELECTRICS

24 V DC control voltage.  
Electronic control unit.  
Serial interface - CAN open according to CiA DS 444 profile.  
4 LED work lights.  
3 indication lights.

### » HYDRAULICS

70-90 l/mn at 160 bar. ISO cleanliness rating 18/16/13 (ISO 4406).

### » SURFACE CONDITIONING

PUR RAL 7021 (black grey) 160/2  
FeSA2.5 with gloss grade 30 +10/-5 for corrosion protection classification  
C3L/C2M according to EN - ISO 12944.

# SLV40 SIDE LIFT SPREADER WITH VERTICAL TWISTLOCKS



*The picture shown is for illustration purpose and may not correspond to the final design.*

- » **FULL BLOCK STACKING WITH HIGHER VISIBILITY**
- » **20' TO 40' AT MAXIMUM SPEED WITH DAMPENING**
- » **ISO TWISTLOCKS**
- » **±600MM SIDE SHIFT UP TO ±3° SELF-LEVELLING**
- » **FULL CANOPEN BUS INTEGRATED MANAGEMENT**
- » **LONGER SERVICE INTERVALS AND LONG ECONOMIC LIFE**

The Bromma SLV40 is a side lift spreader designed to handle single 20ft and 40ft empty containers for masted lifttrucks.

It is designed to offer outstanding visibility to allow rapidly positioning of the twistlock heads to the containers.

SLV40 is equipped with side shift, telescopic, and mechanical pile slope functions that allows it to easily locate containers.

The spreader is designed to integrate optimally to the lifting mast with minimal loss of Load Center.

All spreader movements are controlled with 24V proportional valves, providing precise and smooth operation.

The spreader is operated from the driver's cab over serial communication (CANopen) or parallel wiring. Commands are processed by an electronic control unit on the spreader with built in safety logics for container handling.

## Technical Data SLV40

### » LIFTING CAPACITY (SWL)

9T model = 9 metric tons.  
11T model = 11 metric tons.

### » TARE WEIGHT (TW)

9T model = 3.600 kg (spreader)  
~1.500 kg for sideshift carriage.  
11T model = 4.000 kg (spreader)  
~1.500 kg for sideshift carriage.

### » ISO TWISTLOCKS

90° in less than 1.5 sec.  
Mechanical and electrical safety interlock system.

### » TELESCOPING

20' to 40' in less than 15 sec.  
Analogue or digital sensors for damping and telescoping.

### » SIDE SHIFT

±600 mm with control technology for smooth positioning.

### » MECHANICAL PILE SLOPE

±3° self levelling.  
MPS in side shift carriage in combination with 250 mm float and spring loaded vertical heads.

### » ELECTRICS

24 V DC control voltage.  
Electronic control unit.  
Serial interface, CAN open according to CiA DS 444 profile.  
2 LED work lights.  
3 indication lights.

### » HYDRAULICS

70-90 l/mn at 160 bar.  
ISO cleanliness rating 18/16/13 (ISO 4406).

### » SURFACE CONDITIONING

PUR RAL 7021 (black grey) 160/2  
FeSA2.5 with gloss grade 30 +10/-5 for corrosion protection classification  
C3L/C2M according to EN - ISO 12944.

# SLC40T TWIN LIFT SIDE SPREADER WITH HOOKS AND SIDE CLAMPS

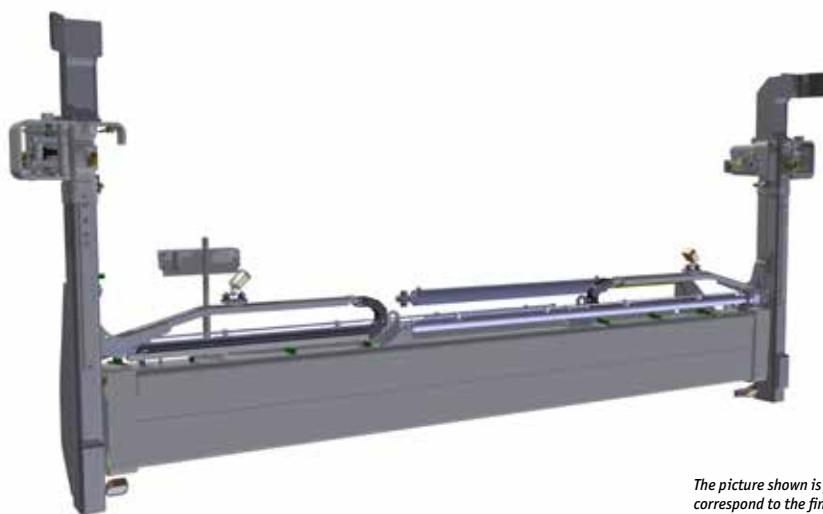

*The picture shown is for illustration purpose and may not correspond to the final design.*

- » **HIGHER VISIBILITY AND BETTER EFFICIENCY**
- » **20' TO 40' AT MAXIMUM SPEED WITH DAMPENING**
- » **SUSPENDED LIFTING HOOKS WITH SIDE CLAMPS**
- » **±600MM SIDE SHIFT**
- » **UP TO ±6° POWERED PILE SLOPE**
- » **FULL CANOPEN BUS INTEGRATED MANAGEMENT**
- » **INTEGRATED MANAGEMENT**
- » **LONGER SERVICE INTERVALS AND LONG ECONOMIC LIFE**

The Bromma SLC40T is a twinlift side spreader for simultaneous handling of two empty containers for masted lift trucks.

The visual contact with the stack, container corners and hooks has been optimized to allow rapid positioning of the lifting heads to the container.

SLC40T is equipped with side shift, telescopic, and mechanical pile slope functions that allows it to easily locate containers. It uses hooks and side clamps to secure the container. The hooks engage the top of the bottom container, and the side clamps lock into the corner castings of both containers.

All spreader movements are controlled with 24V proportional valves, providing precise and smooth operation

The spreader is operated from the driver's cab over serial communication (CANopen) or parallel wiring. Commands are processed by an electronic control unit on the spreader with built in safety logics for container handling.

## Technical Data SLC40T

### » LIFTING CAPACITY (SWL)

9T model = 10 metric tons.  
11T model = 11 metric tons.

### » TARE WEIGHT (TW)

9T model = 4.000 kg (spreader)  
~1.700 kg for sideshift carriage.  
11T model = 4.300 kg (spreader)  
~1.700 kg for sideshift carriage.

### » SUSPENDED LIFTING HOOKS

2 pcs.

### » TELESCOPING

20' to 40' in less than 15 sec.  
A digital sensing of telescoping positions and dampening with maximum speed.

### » SIDE SHIFT

±600 mm with control technology for smooth positioning.

### » POWERED PILE SLOPE

±6°, PPS in sideshift carriage in combination with 250 mm float & springloaded vertical heads.

### » ELECTRICS

24 V DC control voltage.  
Electronic control unit.  
Serial interface, CAN open according to CiA DS 444 profile.  
2 LED work lights.  
4 indication lights.

### » HYDRAULICS

70-90 l/mn at 160 bar.  
ISO cleanliness rating 18/16/13 (ISO 4406).

### » SURFACE CONDITIONING

PUR RAL 7021 (black grey) 160/2  
FeSA2.5 with gloss grade 30 +10/-5 for corrosion protection classification  
C3L/C2M according to EN - ISO 12944.

# TLG40 TOP LIFT SPREADER GANTRY MOUNTING



*The picture shown is for illustration purpose and may not correspond to the final design.*

- » **LOW TARE WEIGHT FOR HIGH PERFORMANCES**
- » **PROPORTIONAL VALVE CONTROL FOR TELESCOPIC, SLEW, REACH AND SIDESHIFT MOTION.**
- » **20' TO 40' AT MAXIMUM SPEED WITH DAMPENING**
- » **FLOATING ISO TWIST LOCKS**
- » **±400MM HYDRAULIC SIDE SHIFT**
- » **±5° SLEW / ±120 MM REACH**
- » **±5° MECHANICAL PILE SLOPE**
- » **FULL CANOPEN BUS INTEGRATED MANAGEMENT**
- » **LONGER SERVICE INTERVALS**
- » **LIGHT AND ROBUST WITH WELL PROVEN DESIGN**

The Bromma TLG40 is a telescopic spreader designed to handle single 20ft and 40ft containers for masted lift trucks fitted with a gantry.

The spreader is designed to attach to the truck gantry with 4 telescopic hangers that is self-levelling.

TLG40 is equipped with side shift, slew, reach telescopic, mechanical pile slope and floating twistlock functions that allows it to easily locate containers.

All spreader movements are controlled with 24V proportional valves, providing precise and smooth operation.

The spreader is operated from the driver's cab over serial communication (CANopen) or parallel wiring. Commands are processed by an Electronic Control Unit on the spreader with built in safety logics for container handling.

## Technical Data TLG40

### » LIFTING CAPACITY (SWL)

45 metric tons, up to ±10% eccentric load.

4 x 10 metric tons, with lifting lugs on the endbeams.

### » TARE WEIGHT (TW)

5.000 kg

### » ISO FLOATING TWISTLOCKS

90° in less than 1.5 sec.

Mechanical and electrical safety interlock system.

### » TELESCOPING

20' to 40' in less than 15 sec. Analogue or digital sensors for damping and telescoping.

### » SLEW

±5° with smooth control technology.

### » REACH

±120 mm with smooth control technology.

### » SIDE SHIFT

±400 mm in less than 8 sec. with smooth control technology

### » MECHANICAL PILE SLOPE

±5° self levelling with 4 telescopic hangers.

### » ELECTRICS

24 V DC control voltage.  
Electronic control unit.  
Serial interface, CAN open according to CiA DS 444 profile.  
2 work lights.  
3 indication lights.

### » HYDRAULICS

70-90 l/mn at 160 bar.  
ISO cleanliness rating 18/16/13 (ISO 4406).

### » SURFACE CONDITIONING

PUR RAL 7021 (black grey) 160/2 FeSA2.5 with gloss grade 30 +10/-5 for corrosion protection classification  
C3L/C2M according to EN - ISO 12944.



# TLF40 TOP LIFT SPREADER STANDARD/INVERTED FORKS MOUNTING



*The picture shown is for illustration purpose and may not correspond to the final design.*

- » **LOW TARE WEIGHT FOR HIGH PERFORMANCES**
- » **PROPORTIONAL VALVE CONTROL FOR TELESCOPIC, SLEW AND REACH**
- » **20' TO 40' AT MAXIMUM SPEED WITH DAMPENING**
- » **FLOATING ISO TWISTLOCKS**
- » **±3° SLEW / ±50 MM REACH**
- » **±5° MECHANICAL PILE SLOPE**
- » **FULL CANOPEN BUS INTEGRATED MANAGEMENT**
- » **LONGER SERVICE INTERVALS**
- » **LIGHT AND ROBUST WITH WELL PROVEN DESIGN**

The Bromma TLF40 is a telescopic spreader designed to handle single 20ft and 40ft containers for masted lift trucks equipped with standard or inverted forks.

The spreader is designed with fork pockets to fit standard or inverted forks. It is latched onto the heels of the forks by pivot arms secured with pins.

The TLF40 is equipped with slew, telescopic, reach mechanical pile slope and floating twistlock functions that allows it to easily locate containers. Additional tilt and side shift are provided by the fork lift truck.

All spreader movements are controlled with 24V proportional valves, providing precise and smooth operation.

The spreader is operated from the driver's cab over serial communication (CANopen) or parallel wiring. Commands are processed by an Electronic Control Unit on the spreader with built in safety logics for container handling.

## Technical Data TLF40

### » LIFTING CAPACITY (SWL)

45 metric tons, up to ±10% eccentric load.  
4 x 10 metric tons, with lifting lugs on the endbeams.

### » TARE WEIGHT (TW)

5.000 kg without extra equipment.  
5.900 kg with slew and reach intermediate carriage.

### » ISO FLOATING TWISTLOCKS

90° in less than 1.5 sec.  
Mechanical and electrical safety interlock system.

### » TELESCOPING

20' to 40' in less than 15 sec.  
Analogue or digital sensors for damping and telescoping.

### » SLEW

±3° with smooth control technology.

### » REACH

±50 mm with smooth control technology.

### » SIDE SHIFT

On fork lift truck.

### » MECHANICAL PILE SLOPE

±5° self levelling .

### » ELECTRICS

24 V DC control voltage.  
Electronic control unit.  
Serial interface, CAN open according to CiA DS 444 profile.  
2 work lights.  
3 indication lights.

### » HYDRAULICS

70-90 l/mn at 160 bar.  
ISO cleanliness rating 18/16/13 (ISO 4406).

### » SURFACE CONDITIONING

PUR RAL 7021 (black grey) 160/2  
FeSA2.5 with gloss grade 30 +10/-5 for corrosion protection classification  
C3L/C2M according to EN - ISO 12944.

